



ROUGH TERRAIN CRANE

TR-350M

JAPANESE SPECIFICATIONS

OUTLINE	SPEC. NO.
5-section Boom, 2-staged Power Tilt Jib	TR-350M-2-00101

Control No. JA-03

TR-350M

CRANE SPECIFICATIONS

CRANE CAPACITY

9.5m Boom	35,000kg	at 3.0m	(10 part-line)
16.15m Boom	22,500kg	at 4.0m	(7 part-line)
22.8m Boom	14,000kg	at 5.5m	(5 part-line)
29.45m Boom	10,000kg	at 7.0m	(4 part-line)
36.1m Boom	7,000kg	at 8.0m	(4 part-line)
8.0m Jib	3,400kg	at 78°	(1 part-line)
13.0m Jib	2,200kg	at 77°	(1 part-line)
Single top	3,400kg		(1 part-line)

MAX. LIFTING HEIGHT

Boom	37.0m
Jib	49.7m

MAX. WORKING RADIUS

Boom	33.0m
Jib	37.4m

BOOM LENGTH

9.5m – 36.1m

BOOM EXTENSION

26.6m

BOOM EXTENSION SPEED

26.6m / 112s

JIB LENGTH

8.0m, 13.0m

MAIN WINCH SINGLE LINE SPEED

126m/min (4th layer)

MAIN WINCH HOOK SPEED

12.6 m/min (10 part-line)

AUXILIARY WINCH SINGLE LINE SPEED

126m/min (4th layer)

AUXILIARY WINCH HOOK SPEED

126m/min (1 part-line)

BOOM ELEVATION ANGLE

0° – 83°

BOOM ELEVATION SPEED

0° – 83° / 53s

SWING ANGLE

360° continue

SWING SPEED

2.6 rpm

WIRE ROPE

Main Winch

16mm × 200m (Diameter×Length)

Spin-resistant wire rope

Auxiliary Winch

16mm × 110m (Diameter×Length)

Spin-resistant wire rope

BOOM

5-section hydraulically telescoping boom of hexagonal box construction

(stages 2: sequential; stages 3,4,5: synchronized)

BOOM EXTENSION

2 double-acting hydraulic cylinder

2 wire rope type telescoping device

JIB

Quick-turn type (2-staged type which stores alongside below the base boom section and extendible from under the boom (with 2nd stage being a pull-out type))

Hydraulic non-stage offset (5°-45°) type

SINGLE TOP

Single sheave. Mounted to main boom head for single line work.

HOIST

Driven by hydraulic motor and via spur gear speed reducer. With free-fall device.

(with operation lever lock device for prevention of misoperation)

Automatic brake (with foot brake for free-fall device)

2 single winches

With flow regulator valve with pressure compensation

BOOM ELEVATION

1 double-acting hydraulic cylinders

With flow regulator valve with pressure compensation

SWING

Hydraulic motor driven planetary gear reducer

Swing bearing

Swing free/lock changeover type

Negative brake

OUTRIGGERS

Fully hydraulic X-type (floats mounted integrally)

Slides and jacks each provided with independent operation device.

Full extended width 6.7m

Middle extended width 5.2m

Minimum extended width 3.8m

OPERATION METHOD

Hydraulic pilot valve operation

MAX. OUTRIGGER LOAD

35.1t

HYDRAULIC PUMPS

2 variable piston pumps

2 gear pumps

HYDRAULIC OIL TANK CAPACITY

450 liters

SAFETY DEVICES

Automatic moment limiter (AML)

Multi-display indication

Over-winding cutout

Working area control device

Outrigger extension width detector

Winch drum lock

Level gauge

Hook safety latch

Hydraulic safety valve

Telescopic counterbalance valve

Elevation counterbalance valve

Power tilt counterbalance valve

Jack pilot check valve

Swing lock

EQUIPMENTS

Heat pump type air-conditioner

Hydraulic oil temperature indication lamp

Radio

Oil cooler

Tactile-type winch drum rotation indicator

Operation pedal for elevating operation

Centralized oiling device (carrier)

Television (option)

Electrically housed side-mirror

CARRIER SPECIFICATIONS

ENGINE

Model MITSUBISHI 6D22 (with turbo charger)
 Type 4-cycle, 6-cylinder, direct-injection, water-cooled diesel engine
 Piston displacement 11,149cc
 Max. output 270PS at 2,200rpm
 Max. torque 107.0kg-m at 1,200rpm

TORQUE CONVERTER

3-element, 1-stage unit (with automatic lock-up mechanism)

TRANSMISSION

Automatic and manual transmission
 Power shift type (wet multi-plate clutch)
 3 forward and 1 reverse speeds (with Hi/Low settings)

REDUCER

Axle dual-ratio reduction

DRIVE

2-wheel drive (4×2) / 4-wheel drive (4×4) selection

FRONT AXLE

Full floating type

REAR AXLE

Full floating type (with no-spin differential)

SUSPENSION

Front Parallel leaf spring type
 Rear Parallel leaf spring type

STEERING

Fully hydraulic power steering
 With reverse steering correction mechanism

BRAKE SYSTEM

Service Brake

Hydro-pneumatic brake
 Disk brake

Parking Brake

Mechanically operated, internal expanding duo-servo shoe type acting on drum at transmission case rear.

Auxiliary Brake

Hydrodynamic retarder
 Electro-pneumatic operated exhaust brake.
 Auxiliary braking device for operations

FRAME

Welded box-shaped structure

ELECTRIC SYSTEM

24 V DC. 2 batteries of 12V (120Ah)

FUEL TANK CAPACITY

300 liters

TIRES

Front 16.00R25☆☆☆(OR)
 Rear 16.00R25☆☆☆(OR)

CAB

Two-man type
 With sun visor and trim
 Rubber mounted type
 Fully adjustable foldable seat
 (with headrest, armrest, seat belt)
 Adjustable handle (tilt, telescoping)
 Roof windshield lock warning
 Intermittent type roof wiper (with washer)

SAFETY DEVICES

Emergency steering device
 Spring lock device
 Rear wheel steering lock device
 Engine over-run alarm
 Overshift prevention device
 Parking brake alarm
 Powered mirror for right side of boom
 Monitor TV for left side of boom

GENERAL DATA

DIMENSIONS

Overall length	11,400mm
Overall width	2,750mm
Overall height	3,590mm
Wheel base	3,800mm
Tread Front	2,265mm
Rear	2,265mm

WEIGHTS

Gross vehicle weight	
Total	31,800kg
Front	15,900kg
Rear	15,900kg

PERFORMANCE

Max. traveling speed	49km/h
Gradeability (tan θ)	0.6
Min. turning radius	5.2m (4-wheel steering) 8.6m (2-wheel steering)

TOTAL RATED LOADS

(1) With outriggers set
(i)

Unit : ton

Outriggers fully extended (360°)												
A B	9.5m	16.15m	22.8m	29.45m	36.1m	C D E	8.0m			13.0m		
							5°	25°	45°	5°	25°	45°
3.0 m	35.0	22.5	14.0			83°	3.4	2.1	1.6	2.2	1.25	1.0
3.5 m	30.6	22.5	14.0	10.0		78°	3.4	2.1	1.6	2.2	1.25	1.0
4.0 m	27.5	22.5	14.0	10.0		77°	3.25	2.1	1.6	2.2	1.25	0.95
4.5 m	24.7	20.7	14.0	10.0	7.0	75°	2.9	1.95	1.5	1.95	1.2	0.85
5.0 m	22.3	19.3	14.0	10.0	7.0	70°	2.3	1.65	1.3	1.55	1.0	0.75
5.5 m	20.3	17.9	14.0	10.0	7.0	65°	1.9	1.45	1.2	1.25	0.9	0.7
6.0 m	18.6	16.8	13.4	10.0	7.0	63°	1.8	1.35	1.15	1.15	0.85	0.65
6.5 m	16.4	15.8	12.5	10.0	7.0	60°	1.6	1.25	1.1	1.05	0.8	0.63
7.0 m	14.5	14.9	11.8	10.0	7.0	56°	1.35	1.15	1.05	0.9	0.7	0.6
8.0 m		13.1	10.6	8.9	7.0	54°	1.15	1.05	1.0	0.85	0.65	0.57
9.0 m		11.2	9.6	8.0	6.3	50°	0.85	0.75	0.75	0.7	0.55	0.55
10.0 m		9.15	8.6	7.2	5.8	47°	0.65	0.6	0.6	0.5	0.45	0.45
11.0 m		7.4	7.7	6.55	5.3	45°	0.5	0.5		0.4	0.4	
12.0 m		6.2	6.75	6.0	4.9	43°	0.4	0.4				
13.0 m		5.2	5.9	5.55	4.5	a(°)	42 ~ 83	46~83		44 ~ 83	46~83	
14.0 m			5.15	5.1	4.15							
15.0 m			4.45	4.6	3.85							
16.0 m			3.9	4.15	3.6							
17.0 m			3.4	3.8	3.35							
18.0 m			3.0	3.4	3.15							
19.0 m			2.55	3.05	2.95							
20.0 m			2.25	2.7	2.7							
22.0 m				2.1	2.3							
24.0 m				1.6	1.85							
26.0 m				1.2	1.45							
28.0 m					1.1							
30.0 m					0.8							
32.0 m					0.6							
33.0 m					0.5							
a(°)	0 ~ 83											

- A = Boom length
- B = Working radius
- C = Jib length
- D = Jib offset
- E = Boom angle
- a = Boom angle range (for the unladen condition)

(ii)

Unit : ton

Outriggers middle extended (Over sides)												
A B	9.5m	16.15m	22.8m	29.45m	36.1m	C D E	8.0m			13.0m		
							5°	25°	45°	5°	25°	45°
3.0 m	35.0	22.5	14.0			83°	3.4	2.1	1.6	2.2	1.25	1.0
3.5 m	30.6	22.5	14.0	10.0		78°	3.4	2.1	1.6	2.2	1.25	1.0
4.0 m	27.5	22.5	14.0	10.0		77°	3.25	2.1	1.6	2.2	1.25	0.95
4.5 m	24.7	20.7	14.0	10.0	7.0	75°	2.9	1.95	1.5	1.95	1.2	0.85
5.0 m	22.3	19.3	14.0	10.0	7.0	70°	2.3	1.65	1.3	1.55	1.0	0.75
5.5 m	19.8	17.9	14.0	10.0	7.0	65°	1.8	1.45	1.2	1.25	0.9	0.7
6.0 m	16.9	15.8	13.4	10.0	7.0	63°	1.5	1.3	1.15	1.15	0.85	0.65
6.5 m	14.3	13.6	12.5	10.0	7.0	60°	1.15	1.0	0.9	0.95	0.75	0.63
7.0 m	12.3	11.7	11.8	10.0	7.0	56°	0.7	0.6	0.55	0.5	0.4	0.4
8.0 m		8.9	9.5	8.9	7.0	54°	0.5	0.4	0.4			
9.0 m		7.0	7.7	8.0	6.3	a(°)	53 ~ 83			55 ~ 83		
10.0 m		5.6	6.3	6.8	5.8		A = Boom length B = Working radius C = Jib length D = Jib offset E = Boom angle a = Boom angle range (for the unladen condition)					
11.0 m		4.6	5.3	5.75	5.3							
12.0 m		3.8	4.4	4.95	4.9							
13.0 m		3.1	3.8	4.3	4.3							
14.0 m			3.3	3.75	3.9							
15.0 m			2.8	3.25	3.45							
16.0 m			2.4	2.8	3.05							
17.0 m			2.0	2.4	2.65							
18.0 m			1.6	2.05	2.3							
19.0 m			1.3	1.75	2.0							
20.0 m			1.0	1.5	1.75							
22.0 m				1.0	1.25							
24.0 m				0.6	0.85							
26.0 m					0.55							
a(°)	0 ~ 83			17~83	41~83							

(iii)

Unit : ton

Outriggers minimum extended (Over sides)												
A B	9.5m	16.15m	22.8m	29.45m	36.1m	C D E	8.0m			13.0m		
							5°	25°	45°	5°	25°	45°
3.0 m	35.0	22.5	14.0			83°	3.4	2.1	1.6	2.2	1.25	1.0
3.5 m	28.5	22.5	14.0	10.0		78°	3.4	2.1	1.6	2.2	1.25	1.0
4.0 m	21.3	20.2	14.0	10.0		77°	3.25	2.1	1.6	2.2	1.25	0.95
4.5 m	16.85	16.1	14.0	10.0	7.0	75°	2.9	1.95	1.5	1.95	1.2	0.85
5.0 m	13.8	13.0	13.8	10.0	7.0	70°	1.75	1.45	1.2	1.4	1.0	0.75
5.5 m	11.6	10.8	11.55	10.0	7.0	66°	0.8	0.7	0.6	0.65	0.55	0.4
6.0 m	9.95	9.15	9.8	10.0	7.0	a(°)	65 ~ 83					
6.5 m	8.5	7.8	8.45	9.0	7.0							
7.0 m	7.4	6.8	7.4	7.95	7.0							
8.0 m		5.15	5.8	6.3	6.4							
9.0 m		4.0	4.65	5.1	5.25							
10.0 m		3.1	3.75	4.2	4.4							
11.0 m		2.35	3.05	3.5	3.65							
12.0 m		1.75	2.5	2.95	3.1							
13.0 m		1.2	2.05	2.45	2.65							
14.0 m			1.65	2.05	2.3							
15.0 m			1.25	1.7	1.95							
16.0 m			0.9	1.35	1.65							
17.0 m			0.6	1.05	1.35							
18.0 m				0.8	1.1							
19.0 m				0.6	0.85							
20.0 m					0.65							
a(°)	0 ~ 83		33~83	46~83	54~83							

- A = Boom length
- B = Working radius
- C = Jib length
- D = Jib offset
- E = Boom angle
- a = Boom angle range (for the unladen condition)

PRECAUTIONS TO BE TAKEN WHEN THE OUTRIGGERS ARE EXTENDED:

1. The total rated loads shown are for the case when the outriggers are set horizontally on firm ground. The values above the bold lines are based on the crane strength while those below are based on the crane stability.
2. The weights of slings and hooks (330kg for a 35 ton capacity hook, 210kg for a 20 ton capacity hook and 70kg for a 3.4 ton capacity hook) are included in the total rated loads shown.
3. The total rated load is based on the actual working radius including the deflection of the boom.
4. The chart below shows the standard number of part lines for each boom length. The load per line should not exceed 3.5t for the main winch and 3.4t for the auxiliary winch.

A	9.5m	16.15m	22.8m	29.45m	36.1m	J
H	10	7	5(6)	4	4	1

The value in () is for a 20t hook.

A = Boom length H = No. of part-line J = Jib / Single top

5. As a rule, free-fall operation should be performed only when lowering the hook alone. If a hoisted load must be lowered by free-fall operation, the load must be kept below 1/5th of the total rated load and sudden braking operations must be avoided.
6. The total rated load for the single top shall be the value obtained by subtracting 250kg from the total rated load of the boom and must not exceed 3.4t.
7. The hoisting performance for the "Over sides" range will differ according to the extended width of the outriggers. Operations should be performed in accordance with the performance corresponding to the extended width. Also, although the hoisting performances for the "Over front" and "Over rear" ranges are equivalent to those of the "outriggers fully extended" condition, the front and rear ranges (angle a) will differ according to the width to which the outriggers are extended in the left and right directions.

Extended width	Middle extended	Minimum extended
Angle a°	25	15

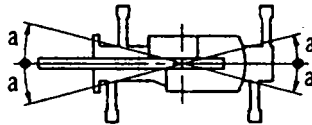

(2) Without outriggers

Unit : ton

B (m)	Stationary						Creep (travelling at 1.6km/h or less)					
	9.5 m BOOM		16.15m BOOM		22.8m BOOM		9.5m BOOM		16.15m BOOM		22.8m BOOM	
	F	G	F	G	F	G	F	G	F	G	F	G
3.0	16.0	9.0	13.0	8.0			12.0	6.8	10.0	6.0		
3.5	16.0	9.0	13.0	8.0			12.0	6.8	10.0	6.0		
4.0	14.4	7.6	13.0	6.75			10.8	5.7	10.0	5.05		
4.5	13.05	6.4	11.8	5.7	10.0	5.5	9.75	4.8	9.15	4.2	7.5	4.0
5.0	11.85	5.2	10.8	4.6	10.0	5.5	8.9	4.05	8.35	3.45	7.5	4.0
5.5	10.8	4.3	9.9	3.7	9.5	4.6	8.15	3.35	7.6	2.8	7.2	3.4
6.0	10.0	3.6	9.1	3.05	9.0	3.9	7.5	2.8	6.95	2.3	6.8	2.85
6.5	8.7	3.0	8.4	2.5	8.3	3.3	6.9	2.35	6.2	1.9	6.2	2.4
7.0	7.5	2.5	7.3	2.0	7.8	2.8	5.9	1.9	5.5	1.55	5.85	2.05
8.0			5.6	1.2	6.25	2.05			4.25	1.0	4.85	1.5
9.0			4.4	0.6	5.05	1.4			3.3	0.5	3.9	1.05
10.0			3.5		4.15	0.9			2.65		3.15	0.75
11.0			2.75		3.4	0.5			2.05		2.6	
12.0			2.1		2.8				1.65		2.15	
13.0			1.6		2.35				1.3		1.8	
14.0					1.9						1.5	
15.0					1.5						1.25	
16.0					1.2						1.0	
17.0					0.9						0.75	
18.0					0.65						0.5	
19.0					0.5							
a(°)	0 ~ 76		47~ 76	18~ 76	56~ 76	0 ~ 76		47~ 76	22~ 76	59~ 76		

B = Working radius F = Front G = 360°

a = Boom angle range (for the unladen condition)

PRECAUTIONS TO BE TAKEN WHEN THE OUTRIGGERS ARE NOT MOUNTED:

1. The total rated loads shown are for the case when the crane is set horizontally on firm ground, with the air pressure of the tires being at the prescribed pressure and with the spring lock being applied completely. The values above the bold lines are based on the tire strength while those below are based on the crane stability. The foundation, working conditions, etc. should be taken into consideration adequately when using the crane for actual work. (Tire air pressure: 9.00kg/cm²).
2. The weights of the slings and hooks are included in the total rated loads shown.
3. The total rated loads are based on the actual working radii into which are included the deflection of the boom and the tires.
4. The chart below shows the standard number of part lines for each boom length. The load per line should not exceed 3.5t for the main winch and 3.4t for the auxiliary winch.

A	9.5 m	16.15m	22.8 m	Single top
H	10	7	5	1

A = Boom length H = No. of part-line

5. The total rated load for the single top shall be the value obtained by subtracting 250kg from the total rated load of the boom and must not exceed 3.4t.
6. Free-fall operations should not be performed without outriggers.
7. Booms over 22.8m in length and jibs should not be used without outriggers.
8. "Over front" crane operations should be performed with the boom being inside a 2° area (1° each to the left and right) over front of the carrier.

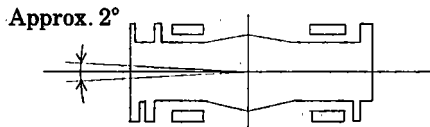

9. When creeping while hoisting a load, the swing brake should be applied, the load should be kept as close to the ground as possible but not touching the ground and the speed should be kept at 1.6km/h or less. In particular, any abrupt steering, starting or braking must be avoided.
10. Crane operations should not be performed when creeping while hoisting a load.

WORKING RADIUS - LIFTING HEIGHT

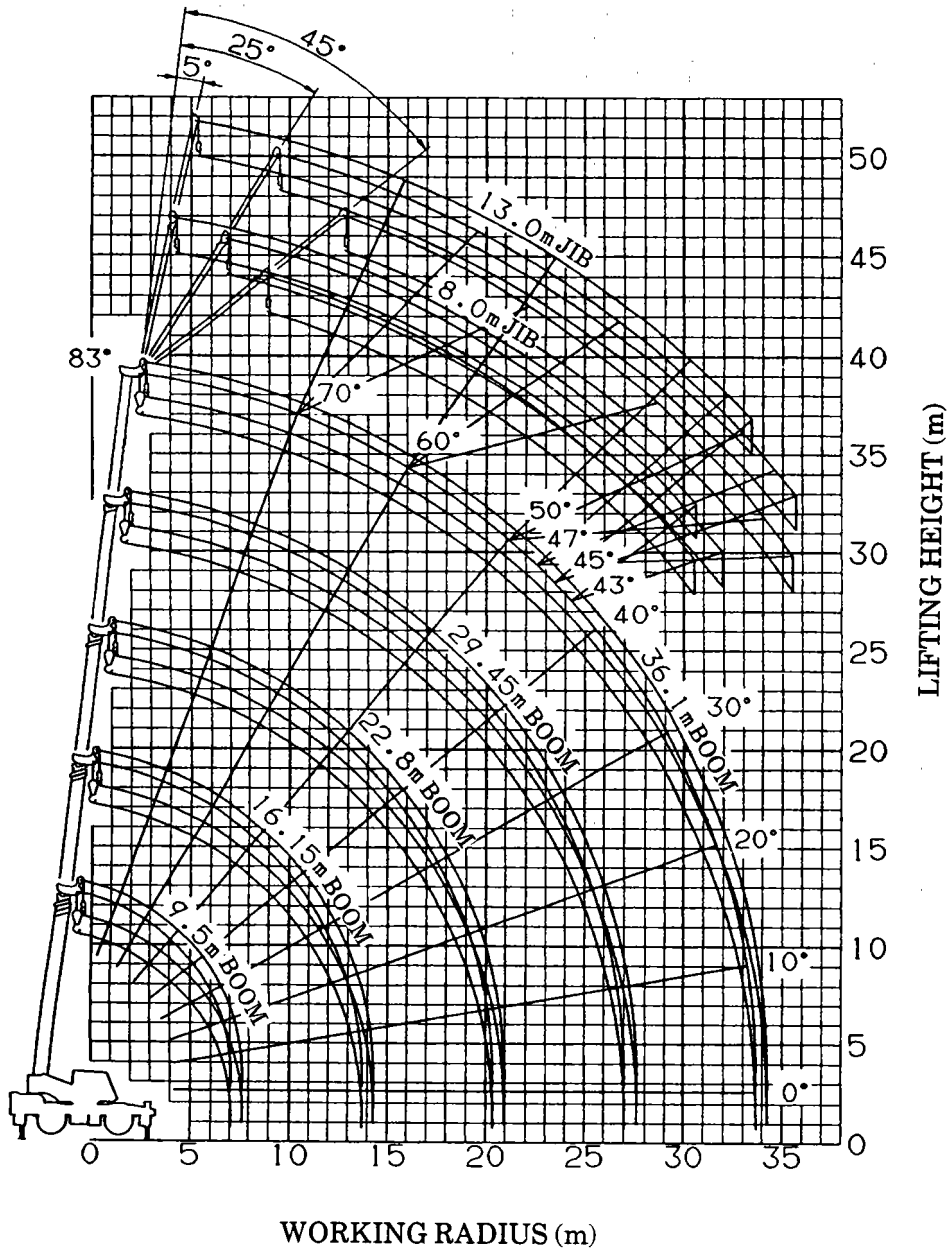

NOTES:

1. The deflection of the boom is not incorporated in the figure above.
2. The figure above is for the case when the outriggers are fully extended (360°).

DIMENSIONS (1/100)

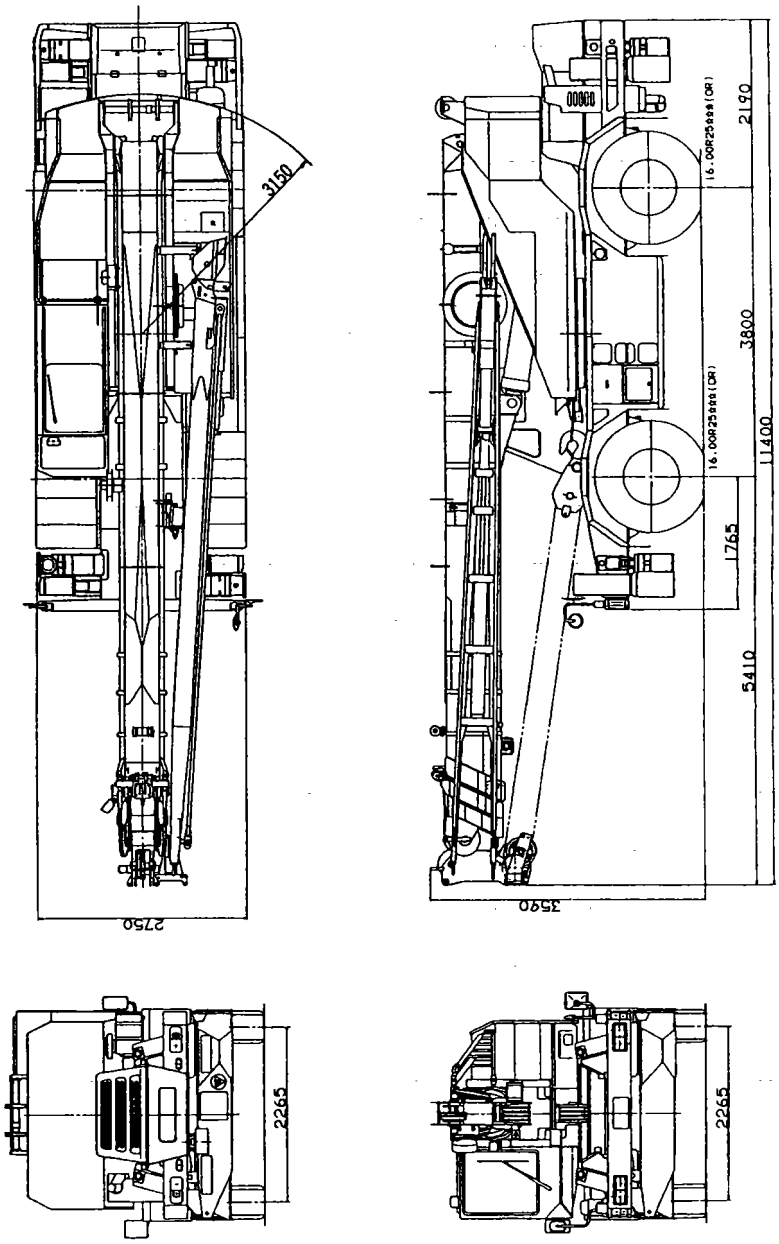

◆ MEMO ◆

A series of horizontal dashed lines for writing a memo.